

---

---

## Internet Modem Using iChip CO661AL-S/20PC-3

---

---

### Introduction

The Internet Modem is based on the iChip™ CO661AL-S Internet Controller™ and a Multi-Tech dialup SocketModem™ (see: <http://www.multitech.com/PRODUCTS/SocketModem/>).

The design is intended to connect to a host device through a standard EIA RS232 serial port. Modem AT commands and iChip AT+i™ commands are accepted at baud rates of 2400 through 230400 bits/sec. The Internet modem may be used as a normal external dialup modem, due to iChip's default Transparent mode, as well as for communicating over high-level Internet protocols.

### Features

- Standard RS232, serial input channel via 9 pin 'D' connector.
- Data and Internet connection through standard PSTN dialup SocketModem.
- Full H/W flow control.
- CD, RING and PWR LED indicators.
- Supports the full SocketModem AT commands.
- Supports iChip AT+i commands for Internet connectivity.

---

### Reference Design

This reference design outlines the required connections to link a 3.3V CO661AL-S iChip Internet Controller with an embedded SocketModem, based on the block diagram in Figure 1.

The reference design is intended to clarify iChip signal connections. It may be used as a general reference with guidelines for hooking up an iChip CO661AL-S to any standard external land-line or cellular modem.

---

### Block Diagram

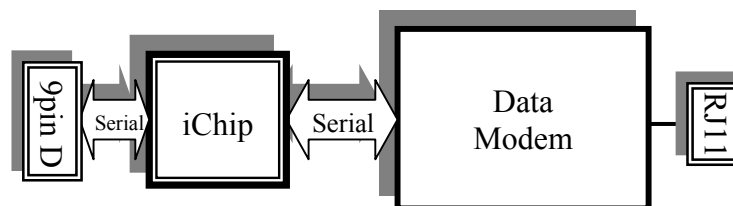

Figure 1: Internet Modem Block Diagram

## iChip Signal Connections

Table 1 defines the required iChip signal connections

Pin Name	#	Connection	
A0 – A18		Must be Not Connected.	Local Bus Signals
D0 – D15		Must be Not Connected.	
-WR	52	Must be Not Connected.	
-RD	68	Must be Not Connected	
-BHE	31	Must be Not Connected	
MMSSEL	64	Should be Pulled-up to VCC. May be connected to GND with a mode select switch.	Miscellaneous Signals
-RES	12	Reset input. Should be connected to reset circuit.	
X1	42	Crystal input. It may be connected to crystal with X2 or connected direct to external clock source.	
X2	43	Crystal input. It may be connected to crystal with X1 or Not Connected when operating on external clock source.	
CLKO/HBT/Z6	44	CLK OUT: can be connected as external clock or heartbeat monitor.	
Z0	14	Should be Not Connected.	
Z1/PCS	21	Should be Not Connected.	
Z2/-POBE	40	Should be Not Connected.	
PWSG/Z3	41	Should be Not Connected.	
Z4	61	Should be Not Connected.	
Z5	62	Should be Not Connected.	
Z7	50	Should be Not Connected.	
-SER/PAR	55	Must connected to GND.	
VCC	1	Power pin. Connect to power supply. Add at least two bypass capacitors of 0.1uF and 1nF.	
GND	67	Power pin. Connect to circuit ground.	
RXDH	30	Connect to output of host (Host TXD signal).	Host Interface Signals
TXDH	26	Connect to input of host (Host RXD signal).	
-CTSH/PIBF	59	<b>H/W Flow Ctl.:</b> Connect to input of host (Host -RTS signal). <b>No H/W Flow Ctl.:</b> Connect to –RTSH (Pin 58).	
-RTSH/-PERR	58	<b>H/W Flow Ctl.:</b> Connect to output of host (Host -CTS signal). <b>No H/W Flow Ctl.:</b> Connect to –CTSH (Pin 59).	
-DTRH	63	Connect to input of host (Host -DSR signal).	
-DSRH/-PRES	15	Connect to output of host (Host -DTR signal). Connect -DSRH to GND when not in use.	
-CDH	60	Connect to input of host (Host -CD signal).	
-RIH	20	Connect to input of host (Host -RI signal).	

Pin Name	#	Connection	Serial Modem Signals
RXDM	28	Connect to output of modem (Modem RXD signal).	
TXDM	29	Connect to input of modem (Modem TXD signal).	
-CTSM	27	<b>H/W Flow Ctl.:</b> Connect to output of modem (Modem -CTS signal) <b>No H/W Flow Ctl.:</b> Connect to -RTSM (Pin 32).	
-RTSM	32	<b>H/W Flow Ctl.:</b> Connect to input of modem (Modem -RTS signal) <b>No H/W Flow Ctl.:</b> Connect to -CTSM (Pin 27).	
-DTRM	18	Connect to input of modem (Modem -DTR signal).	
-DSRM	65	Connect to output of modem (Modem -DSR signal). Connect -DSRM to GND when not in use.	
-CDM	66	Connect to output of modem (Modem CD signal).	

Table 1: iChip Signal Connections

# Internet Modem Schematic

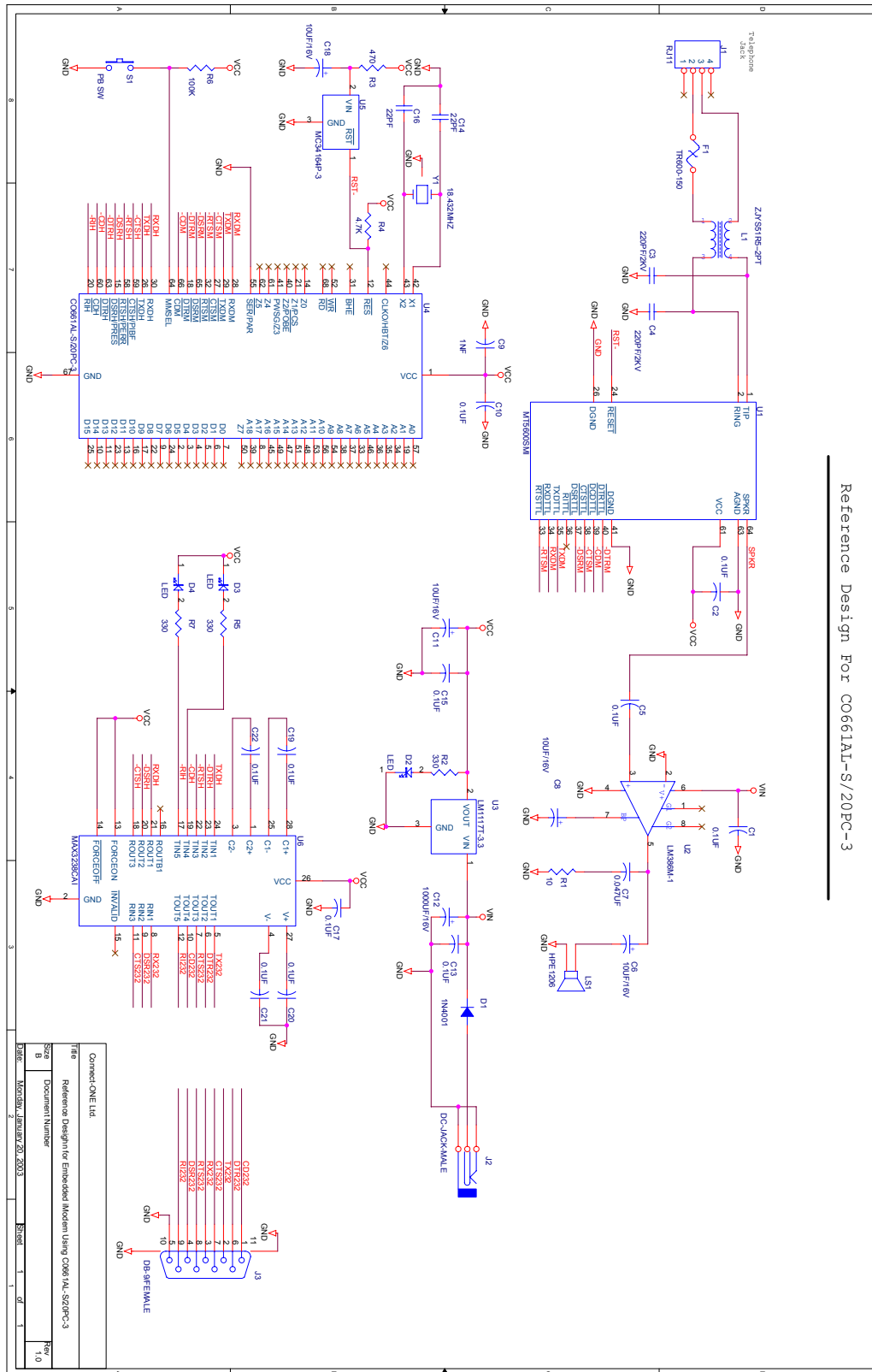

Figure 2: Internet Modem Schematic

### Alternative Reset Circuit

The Reset signal, based on U5 in Figure 2, may be replaced with a low-cost RC network.  $\tau$  should be greater than 10 mSec (see Figure 3):

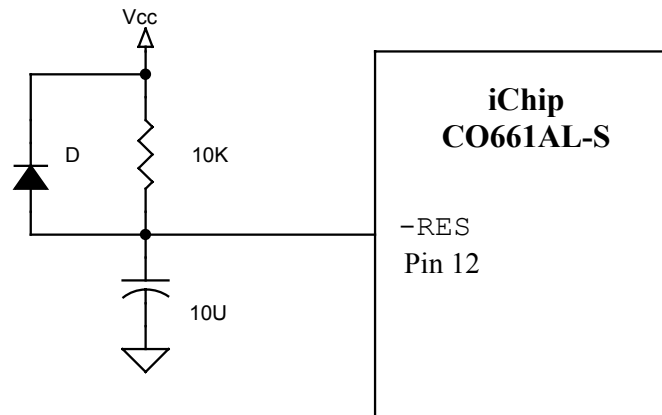

Figure 3: Low-cost RC Reset Circuit

## Bill of Materials for 3.3V Internet Modem Reference Design

#	Qty	Reference Designator	P/N, Description	Manufacturer
1.	11	C1,C2,C5,C10,C13,C15, C17,C19,C20,C21,C22	0.1UF, Ceramic	
2.	2	C3, C4	220PF/2KV GHM3045X7R221K-GC	Murata Erie
3.	4	C6, C8, C11, C18	10UF/16V	
4.	1	C7	0.047UF Ceramic	
5.	1	C9	1NF	
6.	1	C12	1000UF/16V	
7.	2	C14, C16	22PF, Ceramic	
8.	1	D1	1N4001	
9.	3	D2, D3, D4	LED 3MM	
10.	1	F1	TR600-150	RayChem
11.	1	J1	RJ11 - SS-6446-NF-A431	Stewart
12.	1	J2	DC-JACK-MALE	
13.	1	J3	DB-9/FEMALE	
14.	1	LS1	HPE-1206, Speaker 50 $\Omega$	Promover
15.	1	L1	ZJYS51R5-2PT	TDK
16.	1	R1	10	
17.	3	R2, R5, R7	330 $\Omega$	
18.	1	R3	470 $\Omega$	
19.	1	R4	4.7K $\Omega$	
20.	1	R6	100K $\Omega$	
21.	1	S1	PB Switch	
22.	1	U1	MT5600SMI	Multi-Tech
23.	1	U2	LM386M-1	National Semiconductor
24.	1	U3	LM1117T-3.3	National Semiconductor
25.	1	U4	CO661AL-S/20PC-3	Connect One Ltd.
26.	1	U5	MC34164P-3	On Semiconductor
27.	1	U6	MAX3238CAI	Maxim Integrated Products
28.	1	Y1	18.432MHz, parallel resonance, 100ppm	

Table 2: 3.3V Internet Modem Bill of Materials

## **PCB Design and Layout Considerations**

### **Design Consideration**

Good engineering practices must be adhered to when designing a printed circuit board (PCB) containing the SocketModem module. Suppression of noise is essential to the proper operation and performance of the modem itself and for surrounding equipment.

Two aspects of noise in an OEM board design containing the SocketModem module must be considered: on-board/off-board generated noise that can affect analog signal levels and analog-to-digital conversion (ADC)/digital-to-analog conversion (DAC), and on-board generated noise that can radiate off-board.

Both on-board and off-board generated noise that is coupled on-board can affect interfacing signal levels and quality, especially in low level analog signals. Of particular concern is noise in frequency ranges affecting modem performance.

On-board generated electromagnetic interference (EMI) noise that can be radiated or conducted off-board is a separate, but equally important, concern. This noise can affect the operation of surrounding equipment. Most local governing agencies have stringent certification requirements that must be met for use in specific environments.

Proper PC board layout (component placement, signal routing, trace thickness and geometry, etc.), component selection (composition, value, and tolerance), interface connections, and shielding are required for the board design to achieve desired modem performance and to attain EMI certification.

### **PC Board Layout Guidelines**

1. In a 2-layer design, all unused space around and under components should be filled with copper connected to the board ground on both sides of the board, and connected in such a manner as to avoid small islands. Isolated islands should be avoided by connecting all grounds on the same side at several points and to the ground plane on the opposite side through the board at several points. In a modem design, connect the SocketModem DGND and AGND pins to the ground plane.
2. In a 4-layer design, provide an adequate ground plane covering the entire board. In a modem design, SocketModem DGND and AGND pins are tied together on the SocketModem. Do not split analog and digital ground planes.
3. As a general rule, route digital signals on the component side of the PCB and the analog signals on the solder side. The sides may be reversed to match particular OEM requirements. Route the digital traces perpendicular to the analog traces to minimize signals cross coupling.
4. Route the modem signals to provide maximum isolation between noise sources and noise sensitive inputs. When layout requirements necessitate routing these signals together, they should be separated by neutral signals.

5. All power and ground traces should be at least 0.05 in. wide.
6. 0.1 UF ceramic capacitors should be placed as close as possible to the power pins. When internal power plane is used, the traces connecting between the power pins of the components and the vias should be kept short and to have bypass capacitor between the via and the pin.
7. In a modem design, TIP and RING signal traces are to be no closer than 0.062" from any other traces for U.S. applications. TIP and RING signal traces are to be no closer than 2.5mm (0.1") from any other traces for European applications. 2.5mm spacing must be used if the host board is to support both U.S. and European SocketModems. In multi layer design, power and ground planes should be cleared underneath the traces, which belong to the primary (TIP and RING) circuit. Try to avoid vias.
8. In a modem design, if the SocketModem is mounted flush with the host PCB, the host PCB should be clear of all traces directly underneath the SocketModem oscillator section. It is strongly suggested that the SocketModem be mounted at least 0.130 inch above the host board.

### **Electromagnetic Interference (EMI) Considerations**

In a modem design, the following guidelines are offered to specifically help minimize EMI generation. Some of these guidelines are the same as, or similar to, the general guidelines but are mentioned again to reinforce their importance. In order to minimize the contribution of the SocketModem-based design to EMI, the designer must understand the major sources of EMI and how to reduce them to acceptable levels.

1. Keep traces carrying high frequency signals as short as possible.
2. Decouple power from ground with decoupling capacitors as close to the active components' power pins as possible.
3. Eliminate ground loops, which are unexpected current return paths to the power source and ground.
4. Decouple the telephone line cables at the telephone line jacks. Typically, use common mode chokes and shunt capacitors. Methods to decouple telephone lines are similar to decoupling power lines, however, telephone line decoupling may be more difficult and deserves additional attention. A commonly used design aid is to place footprints for these components and populate as necessary during performance/EMI testing and certification.
5. Decouple the power cord at the power cord interface with decoupling capacitors. Methods to decouple power lines are similar to decoupling telephone lines.

6. Locate cables and connectors so as to avoid coupling from high frequency circuits.
7. Avoid right angle turns on high frequency traces. Forty-five degree corners are good, however, radius turns are better.

**Other Considerations in a Modem Design**

The pins of all SocketModem are grouped according to function. The DAA interface, host interface, and LED interface pins are all conveniently arranged, easing the host board layout design. Multi-Tech has tested each of the W.Class SocketModems for compliance with their respective country's PTT requirements and has received PTT certificates that cover, without additional expense to the user, all applications that use these SocketModems in their respective countries. The certificates apply only to designs that route TIP and RING (pins 1 and 2) directly to the telco jack. Only specified EMI filtering components are allowed on these two signals.

**For more information**

Connect One Web site (<http://www.connectone.com/>)

MultiTech Web site (<http://www.multitech.com/PRODUCTS/SocketModem/>).