10/100BaseT LAN and SPI Flash Memory Using iChip™ CO2064SEC

Revision History

Version	Date	Description
1.0	October 2007	Original release

Introduction

This reference design demonstrates the iChip™ CO2064SEC Secure Ethernet Controller connected to a 10/100BaseT Ethernet LAN via an RMI interface, to a host processor via an RS232 interface, and to a flash memory chip via an SPI interface.

LAN access is based on iChip CO2064SEC's internal Ethernet MAC and an external Davicom DM9161A PHY chip (see <http://www.davicom.com.tw/eng/download/datasheet.htm>).

The design is intended to connect to a host device through a standard EIA RS232 serial port. Connect One's AT+i™ commands are accepted at baud rates of 2400 through 115,200 bits/sec.

Features

- Standard RS232 serial input channel
- Data and Internet connection through a 10/100BaseT Ethernet controller
- Full hardware flow control
- Power LED indicators
- Supports AT+i™ commands for Internet connectivity

Reference Design

This reference design outlines the connections required to link an iChip CO2064SEC Secure Ethernet Controller with a 10/100BaseT Ethernet LAN and an external flash memory chip, based on the block diagram, below.

The host is connected to iChip CO2064SEC via an RS232 serial input channel. The external 10/100BaseT Ethernet PHY is connected via an RMI interface. The external flash memory (M25P40-A from ST Micron) is connected via an SPI interface.

Block Diagram

The diagram below illustrates an architecture in which the iChip CO2064SEC loads its firmware from external flash memory. All the components required for this architecture are listed in the Bill of Materials section, below.

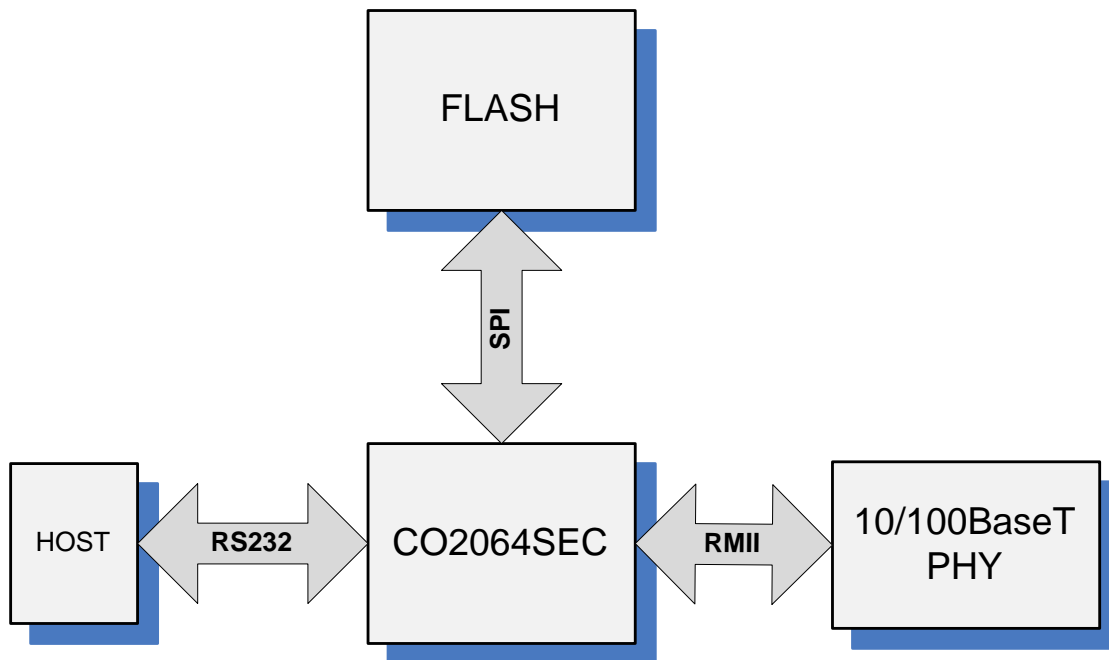

Schematics

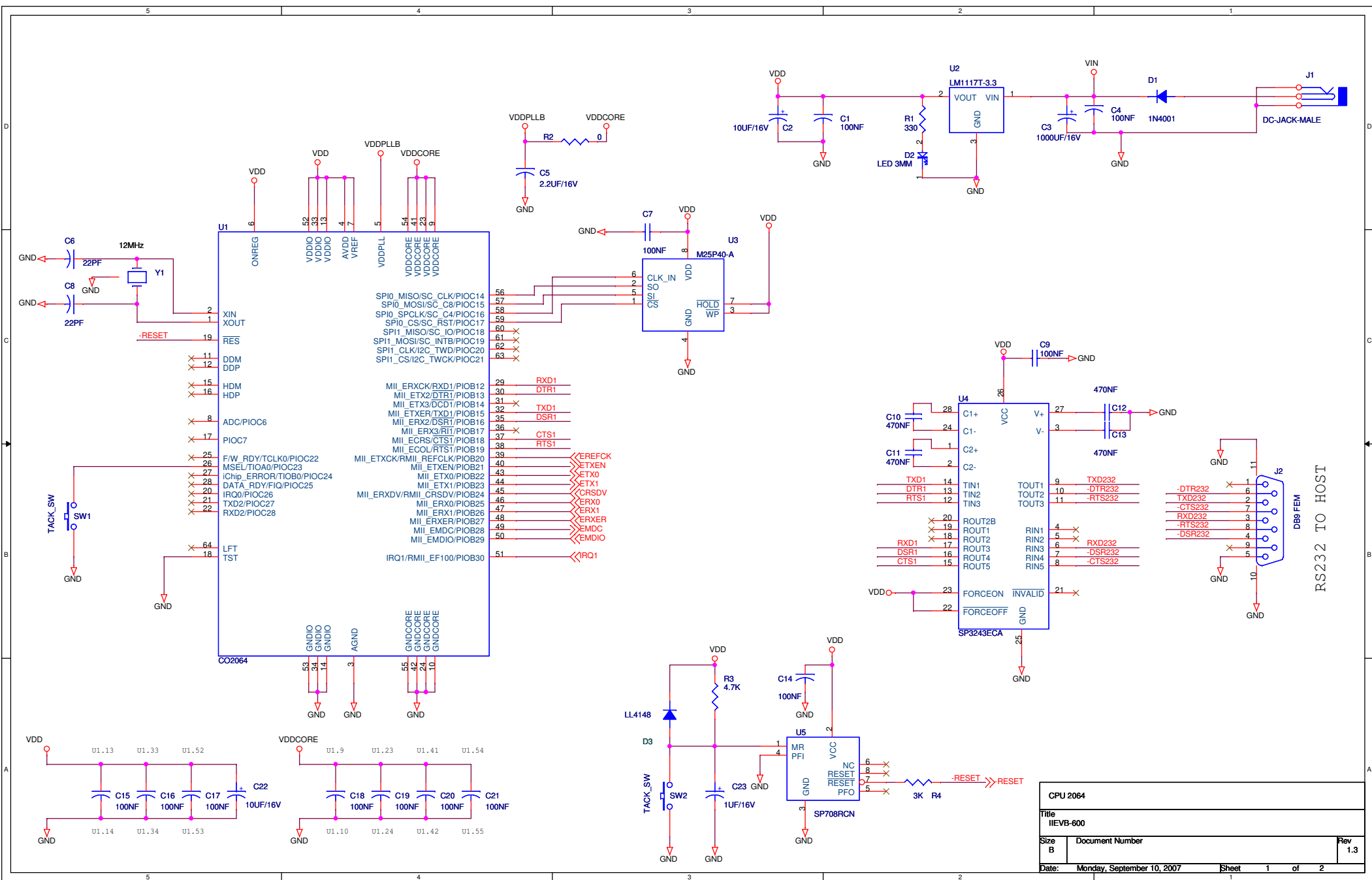

CPU 2064		
Title IIEVB-600		
Size B	Document Number	Rev 1.3
Date: Monday, September 10, 2007	Sheet 1	of 2

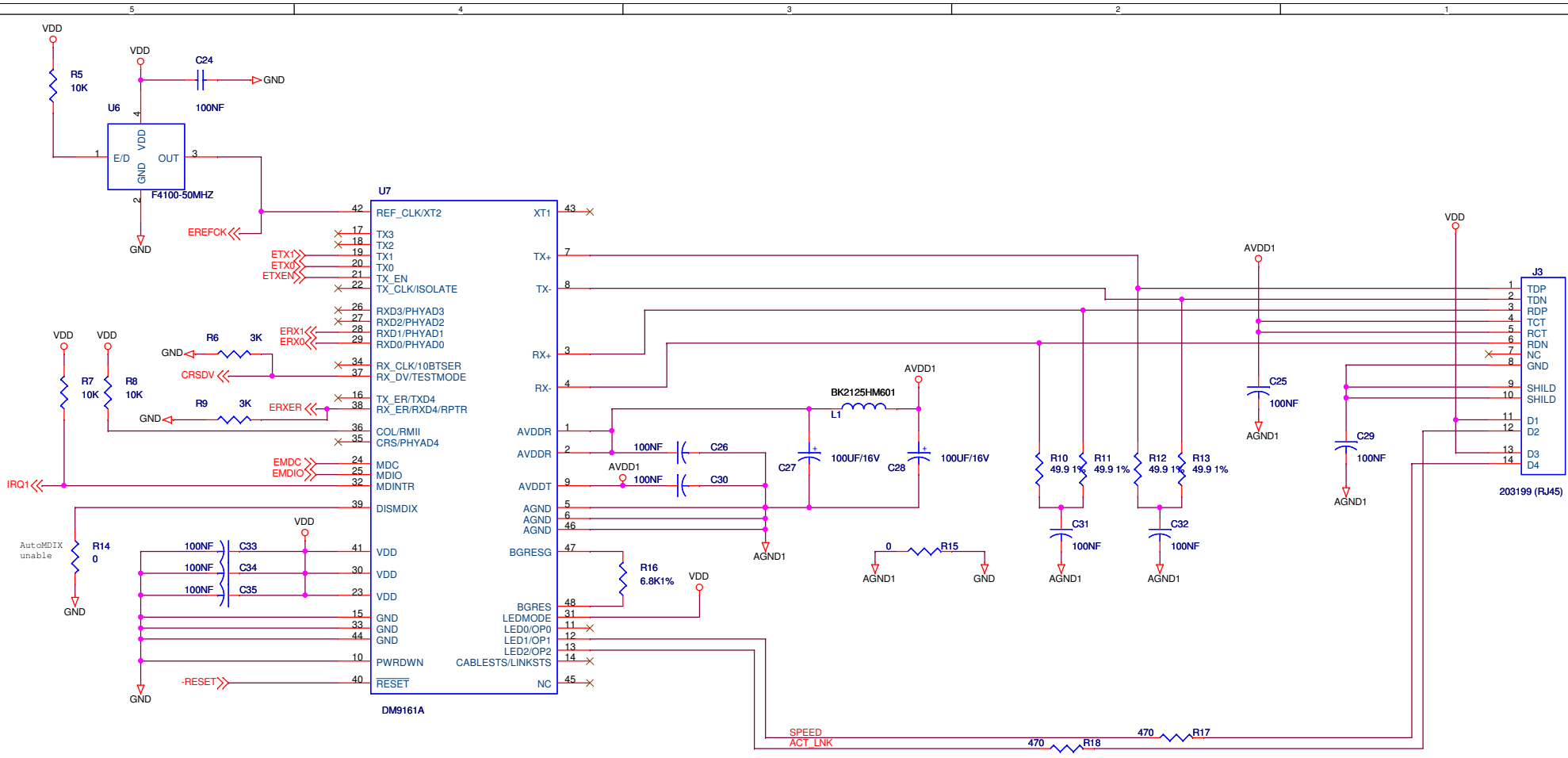

RMII INTERFACE		
Title IIEVB-600		
Size B	Document Number	Rev 1.1
Date: Monday, September 10, 2007	Sheet 2	of 2

Bill of Materials

Item	Quantity	Reference	Part	Manufacturer
1	22	C1, C4, C7, C9, C14, C15, C16, C17, C18, C19, C20, C21, C24, C25, C26, C29, C30, C31, C32, C33, C34, C35	100NF	Any
2	2	C2, C22	10UF/16V	Any
3	1	C3	1000UF/16V	Any
4	1	C5	2.2UF/16V	Any
5	2	C6,C8	22PF	Any
6	4	C10, C11, C12, C13	470NF	Any
7	1	C23	1UF/16V	Any
8	2	C27, C28	100UF/16V	Any
9	1	D1	1N4001	Any
10	1	D2	LED 3MM	Any
11	1	D3	LL4148	Any
12	1	J1	DC-JACK-MALE	Any
13	1	J2	DB9 FEM	Any
14	1	J3	203199 (RJ45)	Erni
15	1	L1	BK2125HM601	Any
16	1	R1	330	Any
17	3	R2, R14, R15	0	Any
18	1	R3	4.7K	Any
19	3	R4, R6, R9	3K	Any
20	3	R5, R7, R8	10K	Any
21	4	R10, R11, R12, R13	49.9 1%	Any
22	1	R16	6.8K1%	Any

Item	Quantity	Reference	Part	Manufacturer
23	2	R17, R18	470	Any
24	2	SW1, SW2	TACK_SW	Any
25	1	U1	CO2064	Connect One
26	1	U2	LM1117T-3.3	National
27	1	U3	M25P40-A	ST Micron
28	1	U4	SP3243ECA	Sipex
29	1	U5	SP708RCN	Sipex
30	1	U6	F4100-50MHZ	Fox
31	1	U7	DM9161A	Davicom
32	1	Y1	12MHZ	Any