Internet Serial to Serial Using iChip CO110PC/66LI-3

Introduction

The Internet serial to serial device is based on the iChip™ CO110PC Internet Controller™. The design is intended to connect to a host device through a standard EIA RS232 serial port. Modem AT commands and iChip AT+i™ commands are accepted at baud rates of 2400 through 230400 bits/sec. The device may be used in a normal external dial-up environment, due to iChip's default Transparent mode, as well as for communicating over high-level Internet protocols.

Features

- Standard RS232, serial input channel via 9 pin 'D' connector.
- Data and Internet connection through standard PSTN dial-up or cellular Modem.
- Full hardware flow control.
- SerialNET LED indicator.
- Supports the full Modem AT commands.
- Supports iChip AT+i commands for Internet connectivity.

Reference Design

This reference design outlines the required connections to link a 3.3V CO110PC iChip Internet Controller to a host processor and an external modem, based on the block diagram in Figure 1.

The reference design is intended to clarify iChip signal connections. It may be used as a general reference with guidelines for hooking up an iChip CO110PC to any standard external landline or cellular modem.

Block Diagram

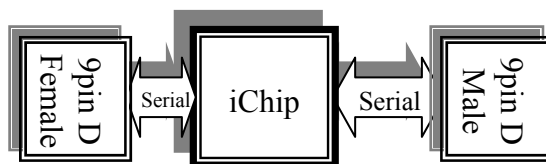

Figure 1: Internet Serial to Serial Block Diagram

iChip Signal Connections

Table 1 defines the required iChip signal connections

Pin Name	#	Connection	
-MSEL	8	Should be Pulled-up to VDDi/o. May be connected to GND through a mode select switch.	Miscellaneous Signals
-FUSEL	44	Should be Pulled-up to VDDi/o. May be connected to GND through a firmware update switch.	
-RESIN	6	Reset input. Should be connected to reset circuit.	
X1	11	Crystal input. May be connected to crystal with X2 or connected directly to external clock source.	
X2	12	Crystal input. May be connected to crystal with X1 or Not Connected when operating on external clock source.	
HBT	9	Not Connected.	
NEWDATA	15	Not Connected.	
VDDcore	5	Power pin. Connect to 1.8VDC power supply. Add at least two bypass filters of 100NF and 1NF.	
VDDi/o	17,40	Power pin. Connect to 3.3VDC power supply. Add at least two bypass filters of 100NF and 1NF.	
GND	7,19, 27,31, 43	Power pin. Connect to circuit ground.	
Z0-Z9	16,10,48, 47,45,41, 38,35,34, 3	Not Connected.	
NC	4,20,25, 26,42	Not Connected.	
RXDH	14	Connect to host output (Host TXD signal).	Host Interface Signals
TXDH	13	Connect to host input (Host RXD signal).	
-CTSH	37	H/W Flow Ctl.: Connect to host input (Host -RTS signal). No H/W Flow Ctl.: Connect to -RTSH (Pin 58).	
-RTSH	39	H/W Flow Ctl.: Connect to host output (Host -CTS signal). No H/W Flow Ctl.: Connect to -CTSH (Pin 59).	

Pin Name	#	Connection	
RXDM	30	Connect to modem output (Modem RXD signal).	Serial Modem Signals
TXDM	29	Connect to modem input (Modem TXD signal).	
-CTSM	36	H/W Flow Ctl.: Connect to modem output (Modem -CTS signal) No H/W Flow Ctl.: Connect to -RTSM (Pin 32).	
-RTSM	1	H/W Flow Ctl.: Connect to modem input (Modem -RTS signal) No H/W Flow Ctl.: Connect to -CTSM (Pin 27).	
-DTRM	2	Connect to modem input (Modem -DTR signal).	
-DSRM	32	Connect to modem output (Modem -DSR signal). Connect -DSRM to GND when not in use.	
-CDM	33	Connect to modem output (Modem CD signal).	
-RIM	46	Connect to modem output (Modem RI signal).	
SCK	22	Not Connected.	
MISO	23	Not Connected.	
MOSI	24	Not Connected.	
SSEL	28	Not Connected.	
SCL	18	Not Connected.	I2C SIGNAL
SDA	21	Not Connected.	

Table 1: iChip Signal Connections

Internet Serial to Serial Device Schematic

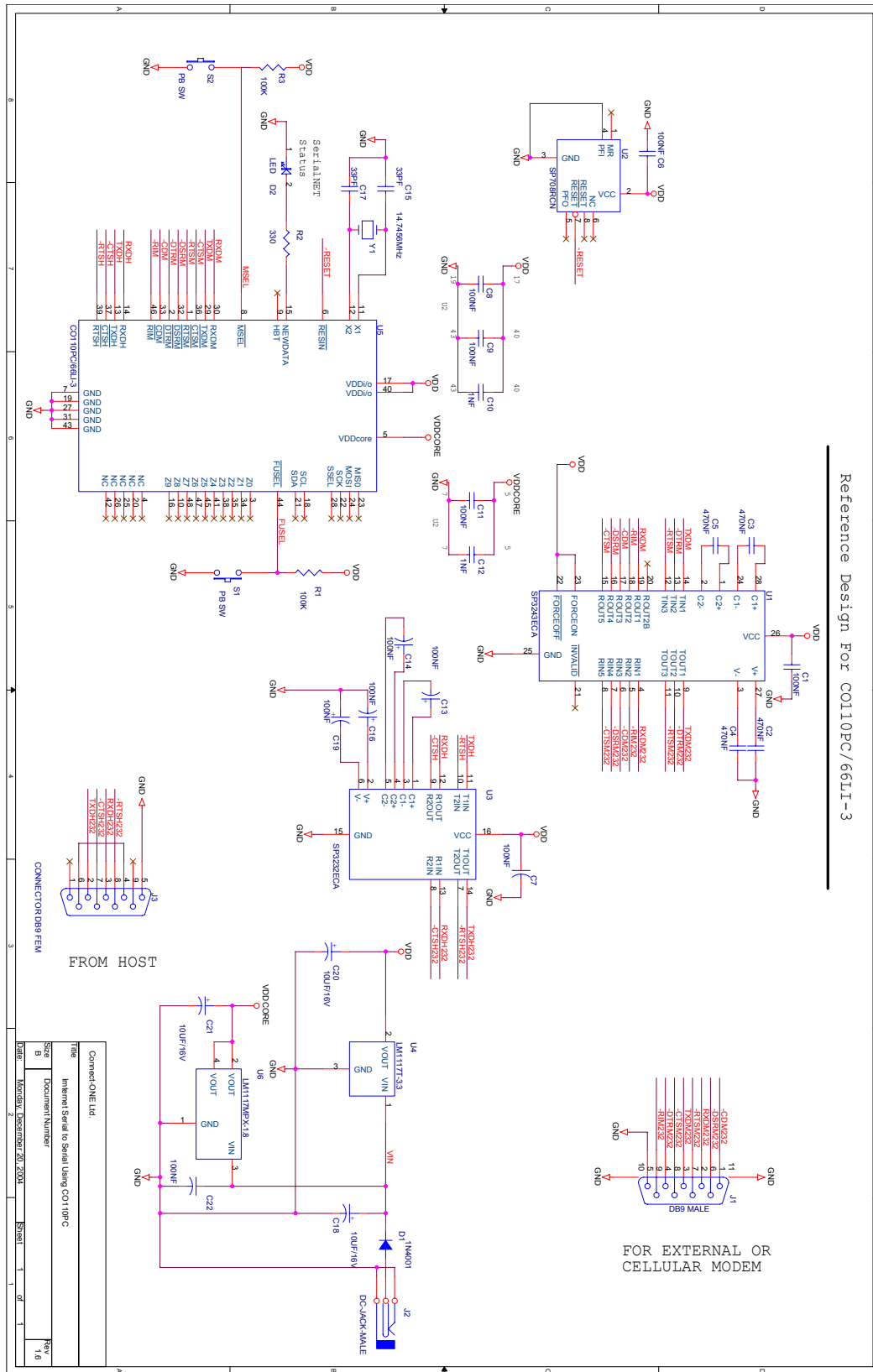

Figure 2: Internet Serial to Serial Schematic

Alternative Reset Circuit

The Reset signal, based on U3 in Figure 2, may be replaced with a low-cost RC network. τ should be greater than 10 mSec (see Figure 3):

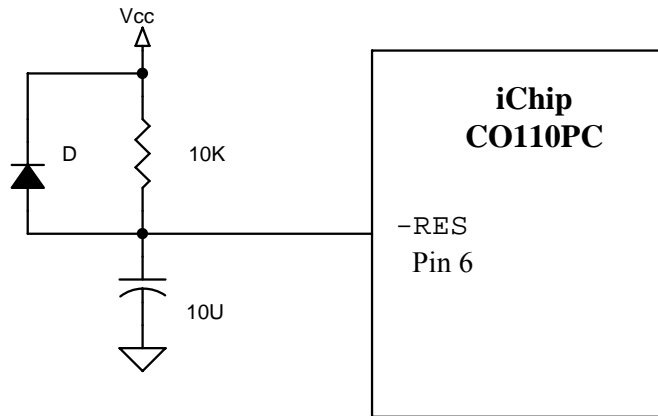

Figure 3: Low-cost RC Reset Circuit

Bill of Materials for Internet Serial to Serial Reference Design

#	Qty	Reference Designator	P/N, Description	Manufacturer
1.	11	C1,C6,C7,C8,C9,C11, C13, C14,C16,C19,C22	100 NF, Ceramic	
2.	4	C2,C3,C4,C5	470 NF Ceramic	
3.	2	C10,C12	1NF	
4.	2	C15,C17	33PF, Ceramic	
5.	3	C18, C20, C21	10UF/16V	
6.	1	D1	1N4001	
7.	1	D2	LED	
8.	1	J1	BD-9/MALE	
9.	1	J2	DC-JACK-MALE	
10.	1	J3	DB-9/FEMALE	
11.	2	R1,R3	100K Ω	
12.	1	R2	330 Ω	
13.	2	S1,S2	PB Switch	
14.	1	U1	SP3243ECA	Sipex
15.	1	U2	SP708RCN	Sipex
16.	1	U3	SP3232ECA	sIPEX
17.	1	U4	LM1117T-3.3	National Semiconductor
18.	1	U5	CO110PC/66LI-3	Connect One Ltd.
19.	1	U6	LM1117MPX-1.8	National Semiconductor
20.	1	Y1	14.7456MHz, parallel resonance, 100ppm	

Table 2: Internet Serial to Serial Bill of Materials